

# EAGLE

## DOWNSTREAM EXTRUSION – COILERS & UNCOILERS

---

**Eagle Model C-2 Haul-off, Coiler Machine** efficiently conveys tubing from an extruder into box containers. The tube is automatically measured to length and coiled into various sizes of box packages. The coiled tube package, upon shipment, can be uncoiled utilizing Eagle's Model UC-2 Uncoiler Machine.

The C-2 Coiler consists of a belt puller, computerized controls, and synchronized offset coil wheels. A slitter is an option that is often used with convoluted tubing.

Eagle's rugged Coiler Machine handles 1/8" to 2" diameter straight tubing, convoluted



### Specifications:

<b>Feed Direction</b>	Right to Left (Standard)
<b>Power Supply</b>	240V, 3-PH, 60Hz
<b>Dimensions</b>	126"L, 39"W, 106"H
<b>Belt Puller</b>	Belt Width 3" 20" Contact Length Digital DC Drive
<b>Control Consul</b>	2.9 to 59 Ft/Min. Belt Speed Computerized, Speed Control, Counter

---

**THE EAGLE GROUP LTD.**

# PRODUCT OVERVIEW

The Eagle Uncoiler Machine, Model UC-2, is designed to uncoil 1/8" to 2" diameter convoluted tubing, straight tubing, and rubber hose.

Model UC-2 Uncoiler Machine efficiently pulls the tube from its container, straightens the tube and then conveys the tube to a cutter where it is cut to length.

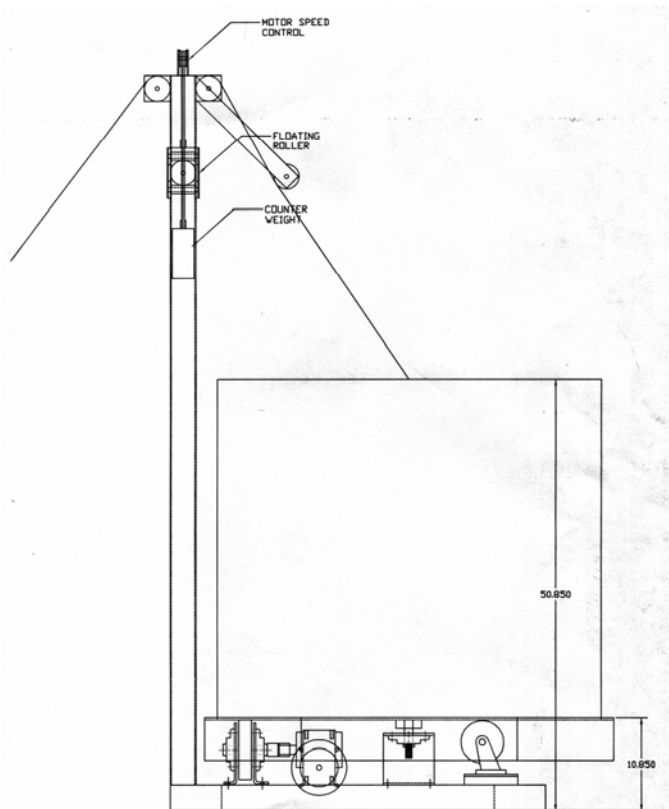

## SPECIFICATIONS:

### Belt Puller

Belt Width

20" Contact

Digital DC Drive

2.9 to 59 Ft./Min. Belt Speed

Computerized, Speed Control, Counter

Enhanced Cut Length Tolerance

Flexible & Semi-Rigid Products

Optional Pneumatic Parts Ejector System

### Control Consul

### Takeaway Conveyor

Parts Collection Tray

and

## THE EAGLE GROUP, LTD.

8384 W. Peck Road  
Greenville, MI 48838

E-mail: [sales@eaglegroupltd.com](mailto:sales@eaglegroupltd.com)

Phone: (616) 754-7777

Fax: (616) 754-1555

Web: [www.eaglegroupltd.com](http://www.eaglegroupltd.com)